

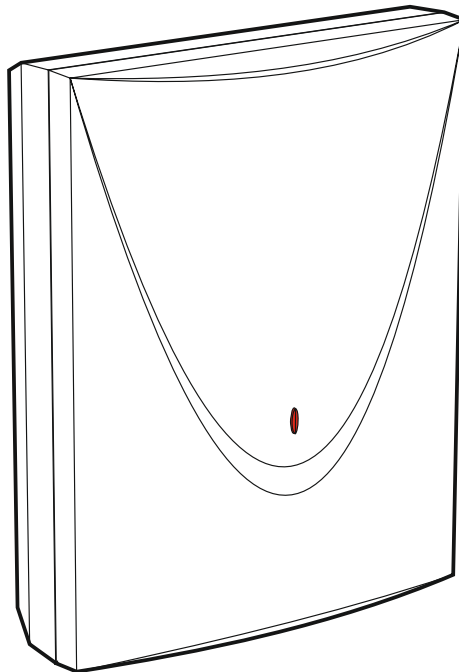

# GSM-X

**Communication module**



## **Quick installation guide**

Full manual is available on [www.satel.eu](http://www.satel.eu)

Firmware version 1.04

gsm-x\_sii\_en 11/21

SATEL sp. z o.o. • ul. Budowlanych 66 • 80-298 Gdańsk • Poland  
tel. +48 58 320 94 00  
[www.satel.eu](http://www.satel.eu)

## IMPORTANT

The module should be installed by qualified personnel.

Prior to installation, please read carefully this manual in order to avoid mistakes that can lead to malfunction or even damage to the equipment.

Disconnect power before making any electrical connections.

Changes, modifications or repairs not authorized by the manufacturer shall void your rights under the warranty.

Connect the module to the **analog telephone line**. Connecting it to a digital network (e.g. ISDN) may cause damage to devices connected to the module.

The name plate of the device is located on the enclosure base.

FreeRTOS is used in this device ([www.freertos.org](http://www.freertos.org)).

SATEL aims to continually improve the quality of its products, which may result in changes in their technical specifications and software. The current information on the introduced modifications is available on our website.

Please visit us:  
<https://support.satel.eu>

**Hereby, SATEL sp. z o.o. declares that the radio equipment type GSM-X is in compliance with Directive 2014/53/EU. The full text of the EU declaration of conformity is available at the following internet address: [www.satel.eu/ce](http://www.satel.eu/ce)**

The following symbols may be used in this manual:



- note,



- caution.

This manual describes how the GSM-X, GSM-X-ETH and GSM-X-PSTN modules should be installed. For further information related to the modules, including their configuration and operation, please refer to the full version of manual, available at [www.satel.eu](http://www.satel.eu)

## 1. GSM-X module installation



**Disconnect power before making any electrical connections.**

**It is not advisable to power up the module if the antenna is not connected.**

**The installation to which the module is to be connected should be provided with:**

- **2-pole disconnector,**
- **short-circuit protection with a 16 A time delay circuit breaker.**

The GSM-X module should be installed indoors, in spaces with normal air humidity. When selecting the mounting location, remember that thick masonry walls, metal partitions, etc. will reduce the range of radio signal. It is not advisable to install the module in close vicinity to electrical installations, because this can result in malfunctioning of the device.

### 1.1 Preparing the cabling

Run the cables to be used for connecting the module with other devices to the module installation place. Do not lay the cables in immediate vicinity of the low-voltage electrical network wires, especially those used for supplying the high-power equipment (such as electric motors).

It is recommended that unshielded non-twisted cable to be used.

### 1.2 Installation of enclosure

The GSM-X module is sold complete with the OPU-2B enclosure.

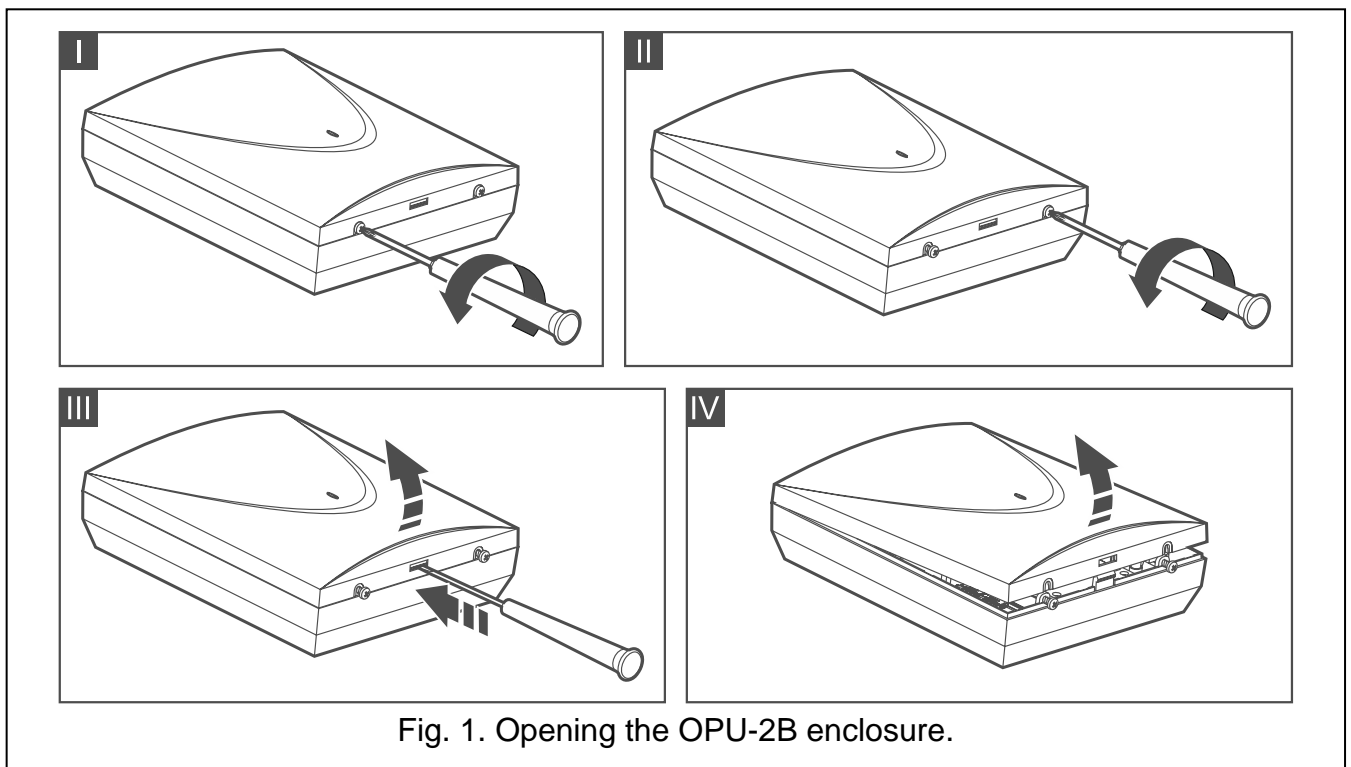



The module can also be installed in SATEL's OPU-4 P enclosure. It is recommended that you use this enclosure, if you are planning to install the GSM-X-ETH Ethernet module / the GSM-X-PSTN telephone module on the electronics board or the module is to be supplied from a power supply unit connected to the APS connector (e.g. APS-412). If the module is installed in the OPU-4 P enclosure, skip the description below and follow instructions contained in the enclosure manual.

1. Loosen the screws locking the enclosure cover and remove the cover (Fig. 1).
2. Put the enclosure against the wall and mark the position of mounting holes.
3. Drill holes for wall plugs (screw anchors) in the wall.
4. Make an opening or openings in the enclosure base for lead-in cables.
5. Run the cables into the enclosure.
6. Using wall plugs (screw anchors) and screws, fasten the enclosure base to the wall. Select wall plugs and screws specifically intended for the mounting surface (different for concrete or brick wall, different for plaster wall, etc.).

### 1.2.1 Elements inside the enclosure

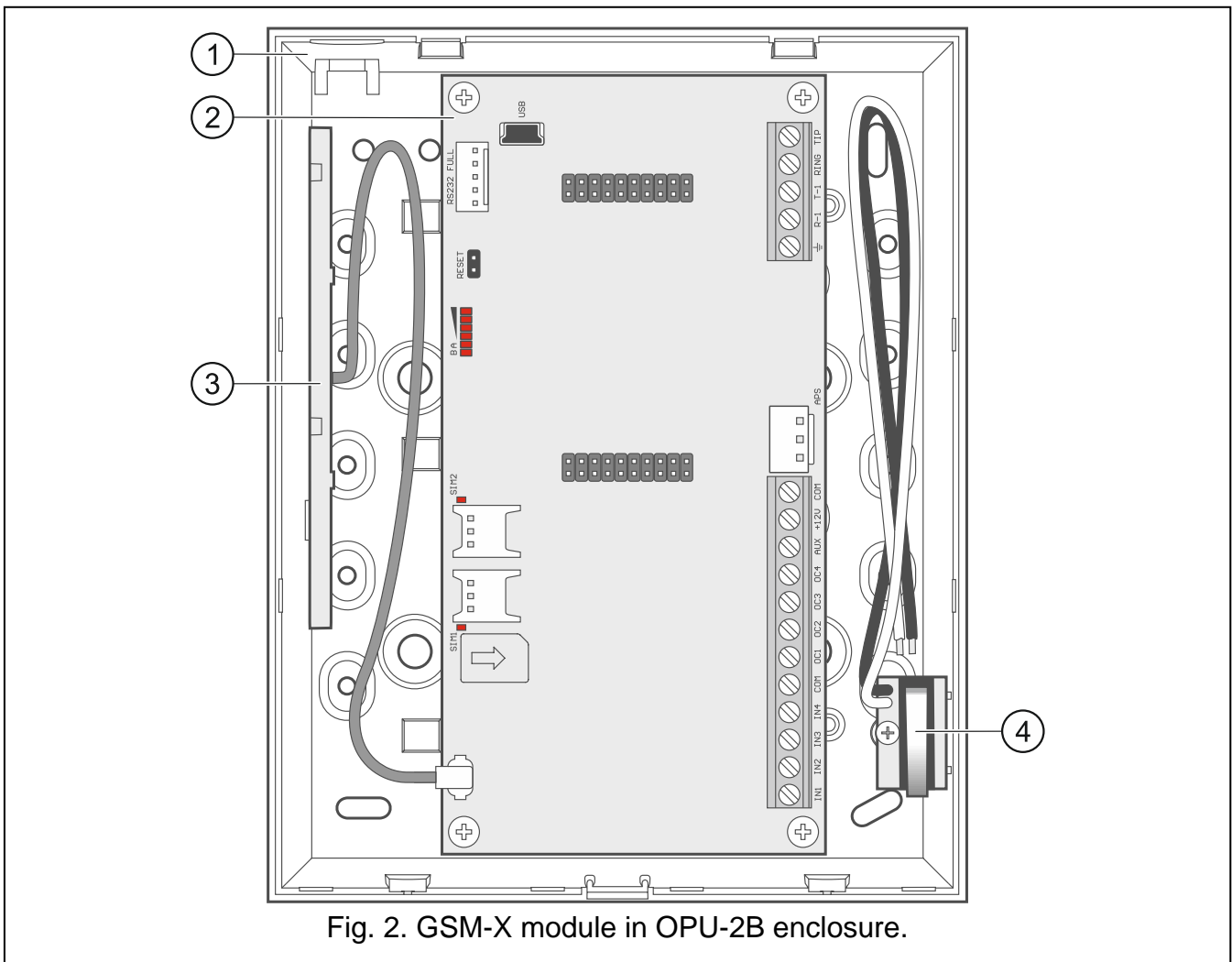

Fig. 2. GSM-X module in OPU-2B enclosure.

- ① enclosure base.
- ② electronics board.
- ③ antenna.
- ④ tamper switch that can be connected to one of the module inputs.

## 1.2.2 Electronics board

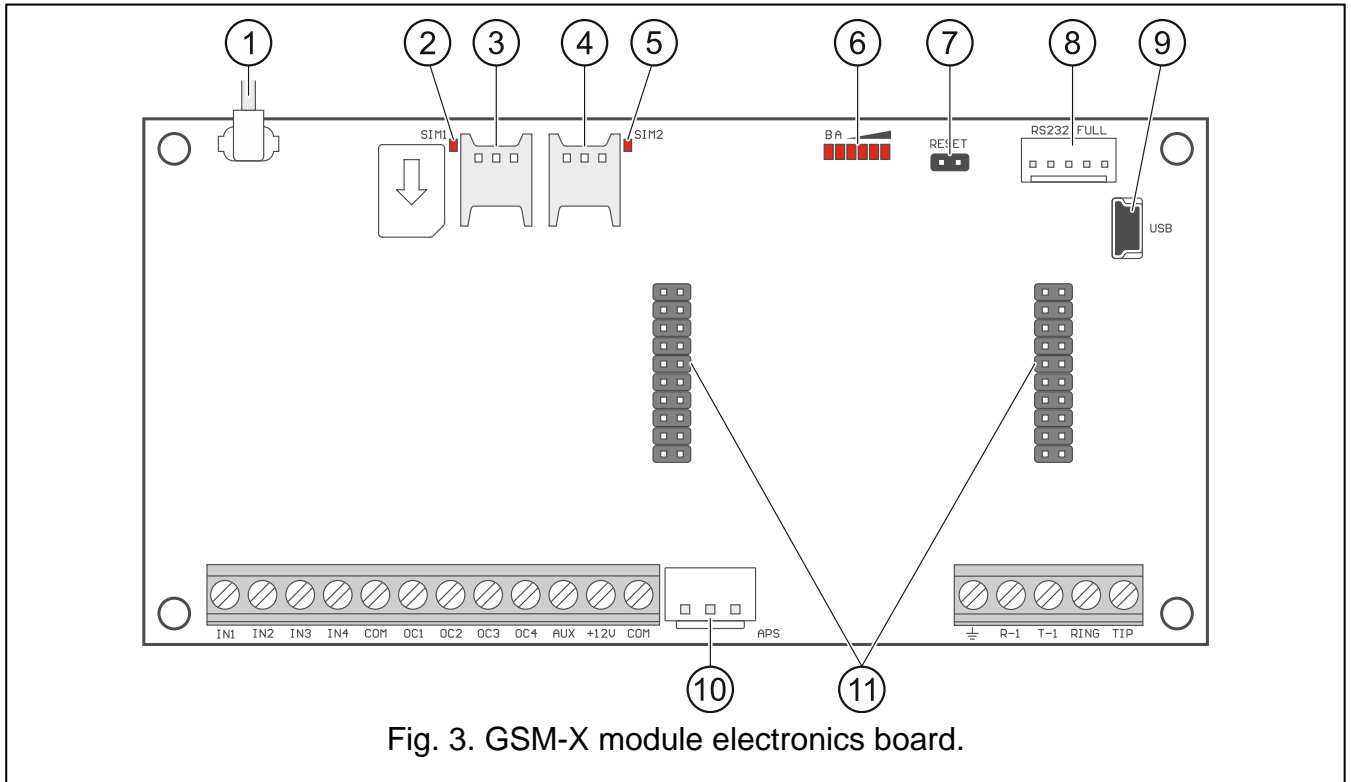

Fig. 3. GSM-X module electronics board.

- ① antenna cable.
- ② SIM1 LED. The LED is on, when the card installed in the SIM 1 slot is active.
- ③ slot in which the first SIM card is to be installed.
- ④ slot in which the second SIM card is to be installed.
- ⑤ SIM2 LED. The LED is on, when the card installed in the SIM 2 slot is active.
- ⑥ LEDs indicating the module status.
- ⑦ RESET pins for emergency update of the module firmware. Shorting the pins enters the module starter mode in which the module is waiting for the firmware update.
- ⑧ RS-232 port.
- ⑨ USB MINI-B socket.
- ⑩ APS connector for a SATEL power supply unit (e.g. APS-412).
- ⑪ connectors for the GSM-X-ETH (see “GSM-X-ETH module installation” p. 7) / GSM-X-PSTN module (see “GSM-X-PSTN module installation” p. 7).

### Description of terminals

**IN1...IN4** – inputs.

**COM** – common ground.

**OC1...OC4** – programmable OC type outputs (disconnected from common ground / shorted to common ground).

**AUX** – +12 VDC power output.

**+12V** – power input (12 VDC  $\pm$ 15%).

$\perp$  – protective terminal of telephone communicator (to be connected only to the PE protective earth circuit of 230 VAC mains).

- R-1, T-1** – analog telephone line output (for connecting a telephone or a device fitted with telephone communicator, e.g. control panel).
- RING, TIP** – analog telephone line input (for connecting the incoming telephone line [from telephone provider] or the GSM-X-PSTN module).

### 1.2.3 Antenna

The GSM-X module is delivered with an antenna installed inside the enclosure. The antenna can be replaced with an external antenna mounted on the enclosure or at some distance from it. If this is the case, you will need the IPX-SMA adapter.

Using the antenna mounted at some distance from the enclosure is recommended wherever thick masonry walls, metal partitions etc. may decrease the range of radio signal at the module installation place.

The antenna must not be installed in parallel to low-voltage electrical wires, or it can affect performance of the antenna.

## 1.3 Connecting the analog telephone line



**The module works only with the analog telephone line.**

**Do not connect any other telephone device between the module and the incoming telephone line.**

**Let the user know how the module is connected to the telephone network.**

Connect the incoming telephone line to terminals RING and TIP (Fig. 4). Any telephone devices located in the premises (telephone, fax, etc.) can be connected to terminals T-1 and R-1.

If the ADSL service is used on the premises where the module is installed, the module should be connected after the ADSL filter, and the other devices using the analog telephone line should be connected to the module (Fig. 5).

To protect the telephone communicator against over-voltage, connect the  $\perp$  terminal to the protective earth conductor (PE) of the 230 VAC mains. To make the connection, use a conductor with  $\geq 0.75 \text{ mm}^2$  cross-section. Never connect the  $\perp$  terminal to the neutral conductor (N).

Additionally, if the GSM-X-PSTN module is to be installed, see “GSM-X-PSTN module installation” p. 7.

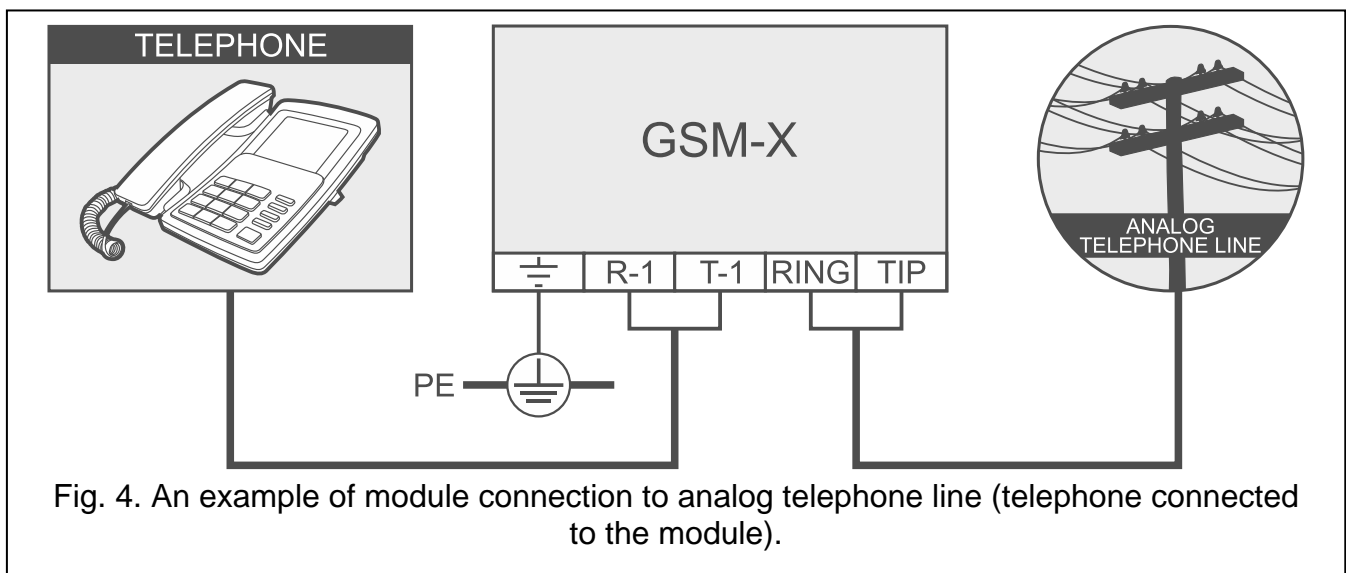

Fig. 4. An example of module connection to analog telephone line (telephone connected to the module).

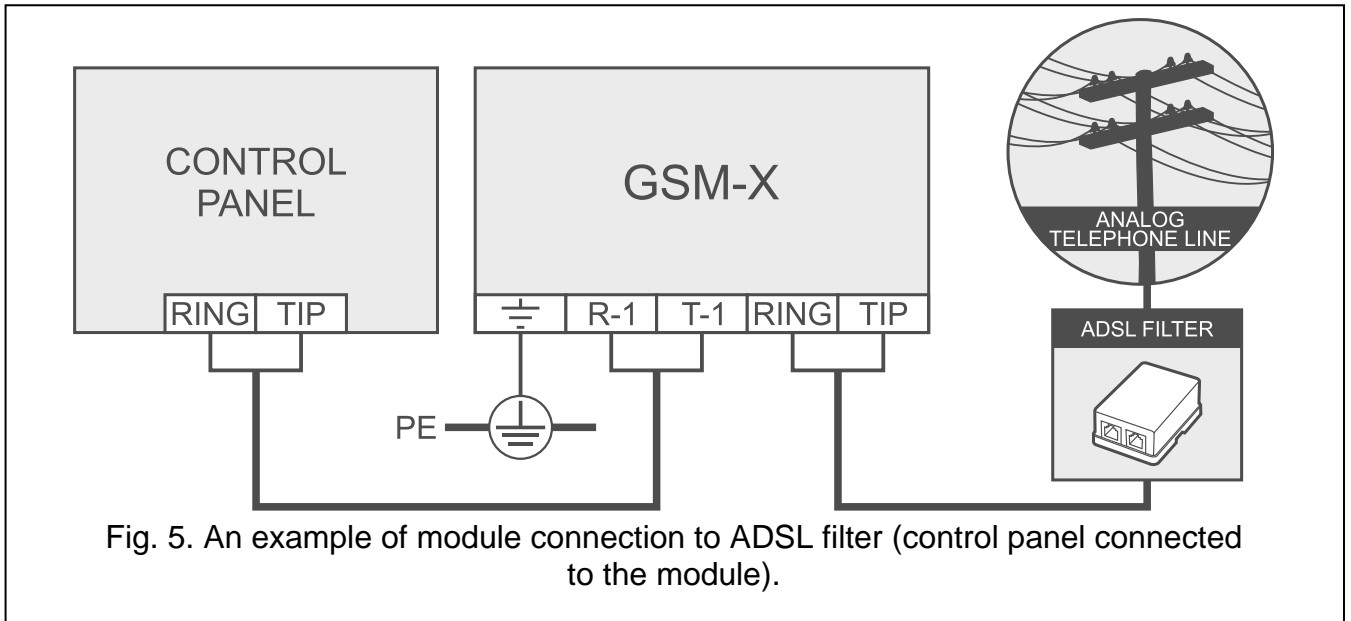

Fig. 5. An example of module connection to ADSL filter (control panel connected to the module).

### 1.4 Connecting the devices to the inputs and outputs

1. Connect the devices whose operation is to be monitored by the module to the input terminals.
2. Connect the devices which are to be controlled by the module to the terminals of OC type outputs.

**i** | The sum of currents drawn by devices powered from the AUX output must not exceed 300 mA.

### 1.5 Connecting the RS-232 port

If the module is to work in conjunction with the INTEGRA / INTEGRA Plus control panel, connect together the RS-232 ports on module and control panel. To connect the module PIN5 connector to the control panel RJ connector, use the RJ/PIN5 cable offered by SATEL.

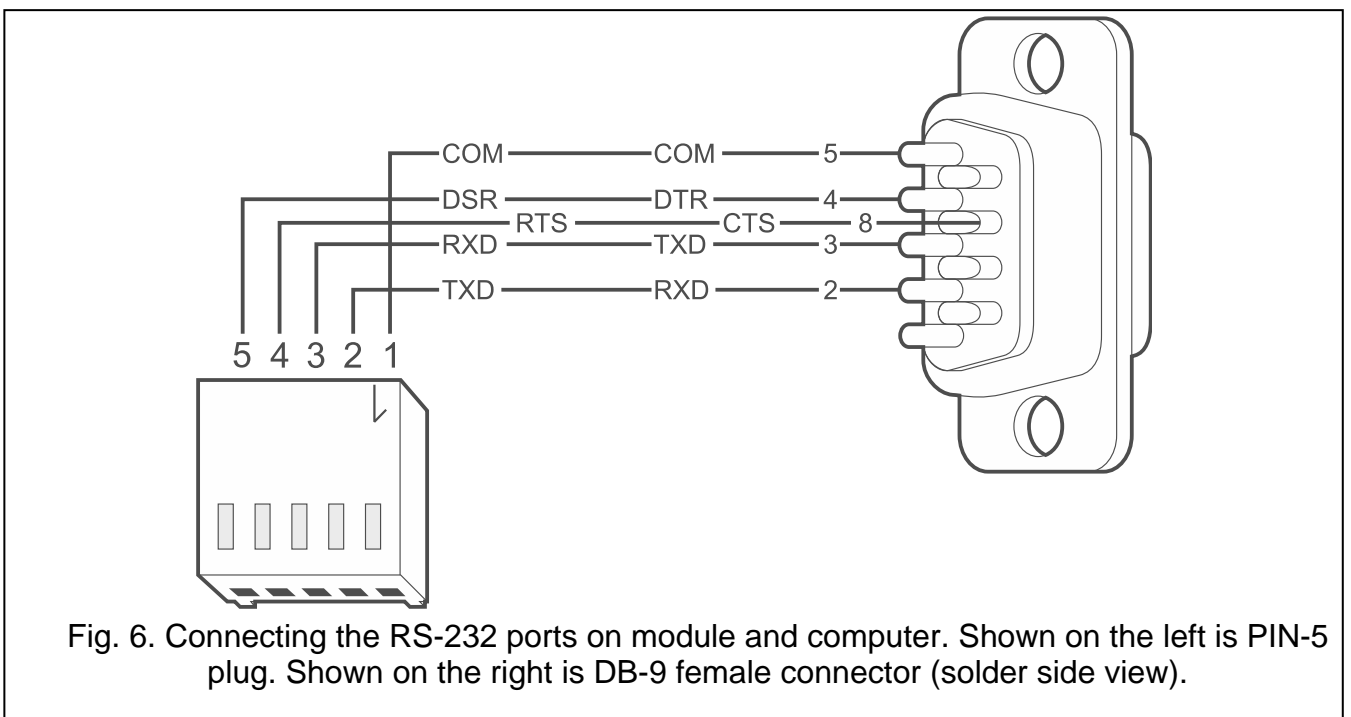

Fig. 6. Connecting the RS-232 ports on module and computer. Shown on the left is PIN-5 plug. Shown on the right is DB-9 female connector (solder side view).

If the module is to work in conjunction with the STAM-2 monitoring station, connect the module RS-232 port to the port of computer on which the cards are installed. If the computer has a RS-232 port, make a connection according to Fig. 6. If the computer has a USB port, use the USB-RS converter available from SATEL.

## 1.6 Connecting the power supply and starting the module

The module may be powered from the control panel, from an expander with power supply, or from a power supply unit. SATEL offers power supplies (e.g. APS-412), which can be connected to the APS connector on the electronics board.



*When the supply voltage drops below 9.8 V, restart of the module occurs.*

*The required output current of power supply is at least 500 mA (provided that no device is powered from the module AUX output).*

1. Depending on the selected method of module powering, connect the power supply unit to the APS connector or connect the power leads to the +12V and COM terminals (use flexible conductors with a cross-section of 0.5-0.75 mm<sup>2</sup>, or rigid conductors with a cross-section of 1-2.5 mm<sup>2</sup>).



**Never connect power supply to APS connector and terminals at the same time.**

2. Power up the module. The module will start up.

## 1.7 Connecting the computer to the module

Connect the computer to the module USB MINI-B connector. Having connected the computer to the module, you can:

- configure the module by using the GX Soft program. You can download the GX Soft program from the [www.satel.eu](http://www.satel.eu) website. Required program version: 2.0 (or newer). See full manual for more information.
- update the module firmware (see full manual of the module).

## 1.8 Installing the SIM cards

You can install up to two nano-SIM cards in the module.

1. If PIN code(s) is / are required by the SIM card(s), use the GX Soft program to program the code(s).
2. Power down the module.
3. Insert the SIM card / cards into the socket / sockets (Fig. 7).

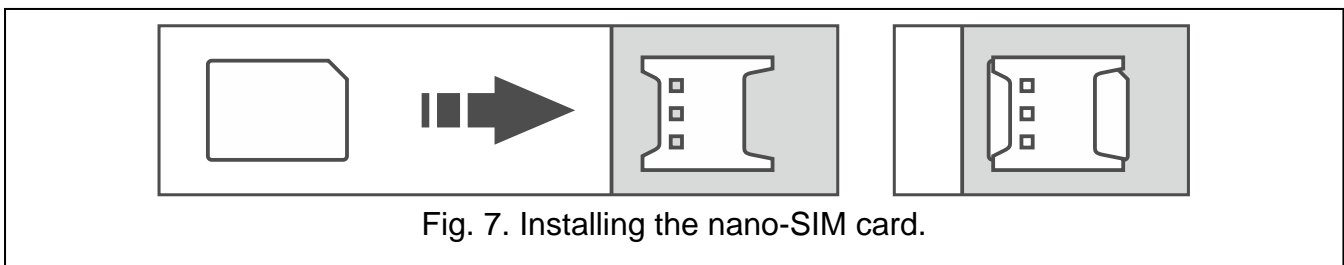

Fig. 7. Installing the nano-SIM card.

4. Power up the module. Logging the telephone into the cellular network may take a few minutes.



*If the module is to send data via the cellular network, it is recommended that you use SIM cards with a dedicated tariff plan for M2M (machine-to-machine) communication.*

*If the programmed PIN code is invalid, the module will report a trouble. Programming a correct PIN code will clear the trouble.*



*Restarting the module with a wrongly programmed PIN code three times will block the SIM card. To unblock the SIM card, remove it and insert into a mobile phone. Then, enter the PUK code.*

## 2. GSM-X-ETH module installation

The GSM-X-ETH Ethernet module enables the GSM-X module to be expanded by adding the Ethernet link.



**The device is designed to be used only in the local area networks (LAN). It must not be connected directly to the public computer network (MAN, WAN). For establishing connection with public networks, use a router or xDSL modem.**

1. Use the GX Soft program to configure settings of the GSM-X-ETH Ethernet module (see full manual of the GSM-X module).
2. Power down the GSM-X module.
3. Install the GSM-X-ETH Ethernet module in the connectors on the GSM-X module electronics board (Fig. 8).

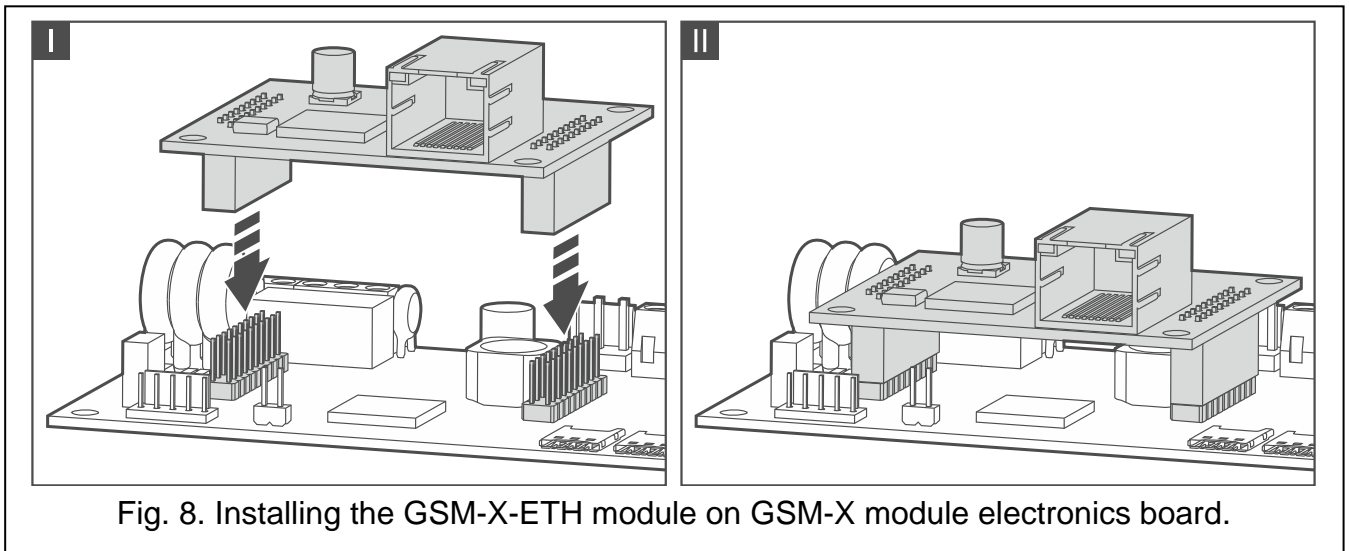

Fig. 8. Installing the GSM-X-ETH module on GSM-X module electronics board.

4. Connect the Ethernet cable to the RJ-45 connector on GSM-X-ETH module. Use a 100Base-TX standard compliant cable, identical to that used for connecting computers to the network.
5. Power up the GSM-X module.

## 3. GSM-X-PSTN module installation

The GSM-X-PSTN module is used to connect the analog telephone line (PSTN).



**The module works only with the analog telephone line.**

**Do not connect any other telephone device between the module and the incoming telephone line.**

**Let the user know how the module is connected to the telephone network.**

1. Use the GX Soft program to enable the GSM-X-PSTN telephone module support (see the full manual to the GSM-X module).
2. Power down the GSM-X module.

3. Install the GSM-X-PSTN module in the connectors on the GSM-X module electronics board (Fig. 9).

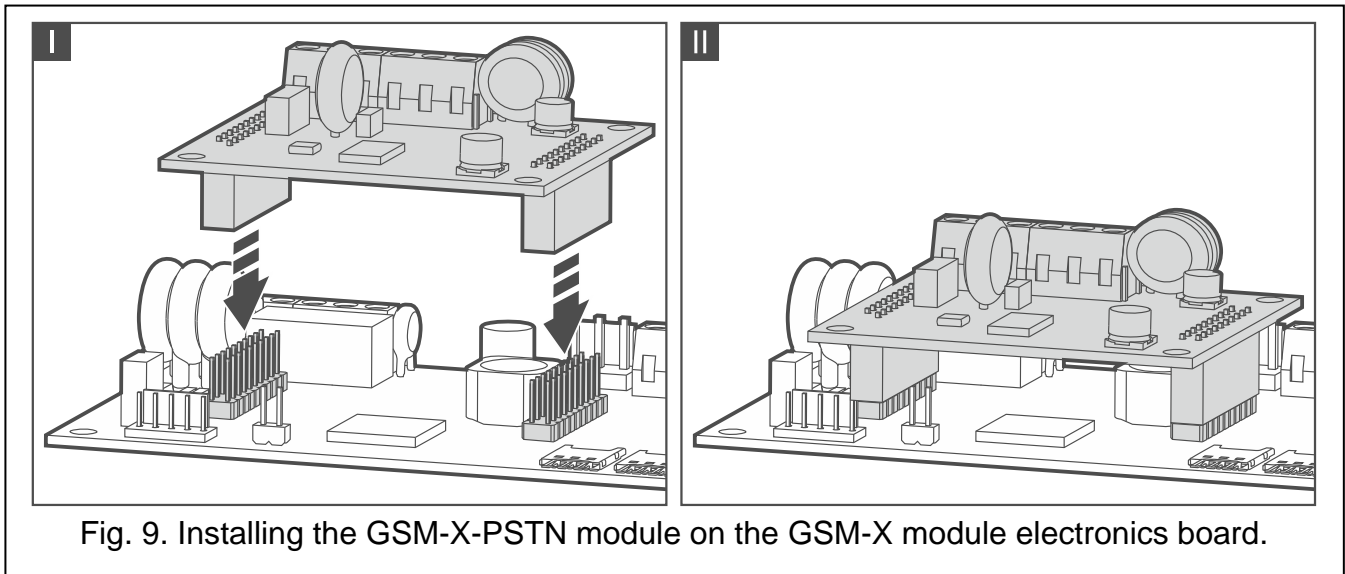

4. Connect terminals T-1 and R-1 of the module to terminals TIP and RING of the GSM-X module (Fig. 10).
5. Connect the incoming telephone line to terminals TIP and RING. If the ADSL service is used on the premises, the module should be connected after the ADSL filter (Fig. 10).
6. Connect terminals T-1 and R-1 of the GSM-X module to terminals TIP and RING of the control panel (Fig. 10). Any telephone located on the premises can be connected to terminals T-1 and R-1 of the control panel.
7. Connect terminals  $\perp$  of the GSM-X and GSM-X-PSTN modules to the protective earth conductor (PE) of the 230 VAC mains (Fig. 10). To make the connection, use a conductor with  $\geq 0.75 \text{ mm}^2$  cross-section. Never connect the  $\perp$  terminal to the neutral conductor (N).
8. Power up the GSM-X module.

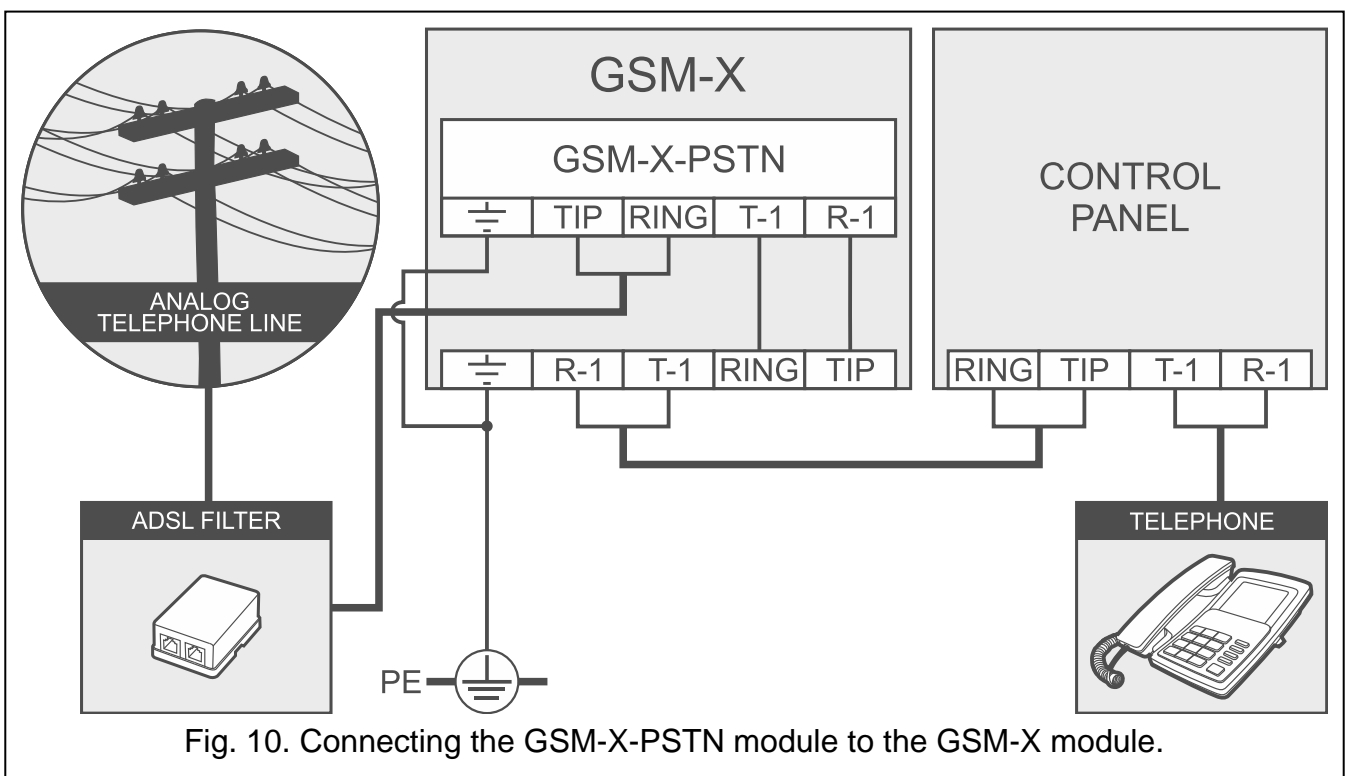

## 4. Specification

---

### GSM-X

Number of inputs .....	4
Number of outputs:	
OC type .....	4
power supply.....	1
Supply voltage .....	12 VDC $\pm$ 15%
Standby current consumption .....	100 mA
Maximum current consumption.....	275 mA
OC type outputs.....	50 mA / 12 VDC
AUX output .....	300 mA / 12 VDC
Environmental class according to EN50130-5 .....	II
Operating temperature range.....	-10...+55°C
Maximum humidity .....	93 $\pm$ 3%
Electronics board dimensions .....	141 x 70 mm
Enclosure dimensions.....	126 x 158 x 46 mm
Weight.....	255 g

### GSM-X-ETH

Standby current consumption .....	25 mA
Maximum current consumption.....	25 mA
Environmental class according to EN50130-5 .....	II
Operating temperature range.....	-10...+55°C
Maximum humidity .....	93 $\pm$ 3%
Electronics board dimensions .....	61 x 51 mm
Weight.....	25 g

### GSM-X-PSTN

Standby current consumption .....	20 mA
Maximum current consumption.....	45 mA
Environmental class according to EN50130-5 .....	II
Operating temperature range.....	-10...+55°C
Maximum humidity .....	93 $\pm$ 3%
Electronics board dimensions .....	61 x 51 mm
Weight.....	25 g