

MNT-410-W

Fisheye-PTZ Integrated Bracket



Features

- Neat & Integrated design, wall mount and hidden line design.
- Material: Aluminum.
- Support linkage scheme between fisheye and speed dome, integrated installation.
- Multi-dimensional adjustment, able to meet Omni-directional observation requirements from different angles.
- Safety rope hook attached, secure and reliable.
- Maintenance cover board attached, convenient operation.

Camera Mount Series | MNT-410-W

Technical Specifications

| Model | MNT-410-W |
|-------------------------------|---|
| General | |
| Material | Aluminum |
| Dimension | Rotation angle 0° : 651.6mmx164.8mmx154.9mm (25.7"x6.5"x6.1") Rotation angle 88° : 555mmx236.9mmx154.9mm (21.8"x9.3"x6.1") |
| Adjustment angle (Vertical) | 0° ~88° |
| Adjustment angle (Horizontal) | 0° ~360° |
| Load Bearing | Fisheye: 1kg (2.2lb) PTZ: 7kg (15.43lb) |
| Weight | 2.8kg (6.17lb) |
| Color | White |
| Operating Temperature | -40°C ~60°C(-40°F ~+140°F) |
| Humidity | 0~90% RH |

Dimensions (mm/inch)

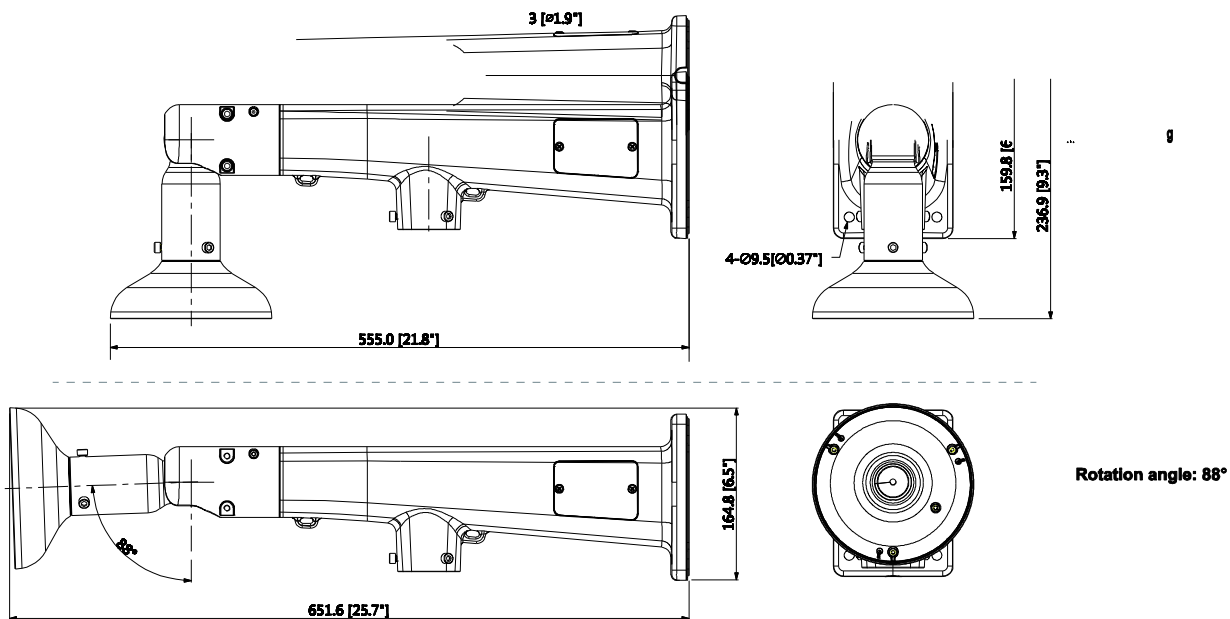

Application

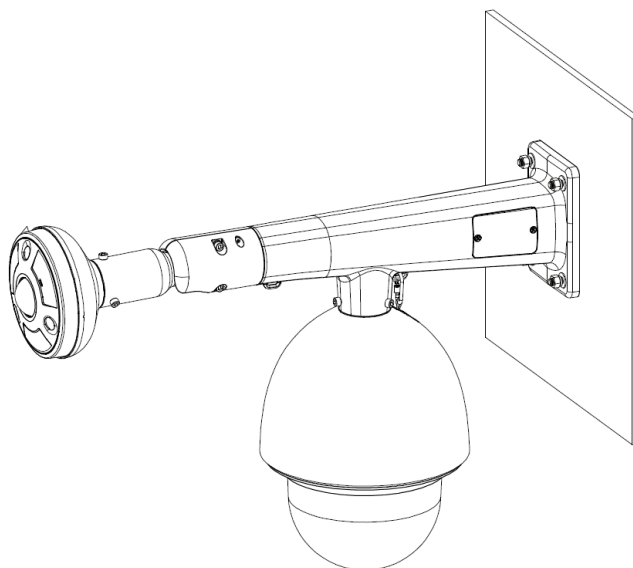

Package Information

- Integrated bracket *1
- Fisheye adapter plate *1
- Application manual *1
- Wrench *1

| Package data | |
|--------------------------|---|
| Box Dimension | 637mm x 207mm x 215mm (25.1" x 8.15" x 8.5") |
| Box Weight | 3.4kg (7.5lb) |
| Protective Box Dimension | 664mm x 444mm x 476mm (26.14" x 17.5" x 18.74") |
| Box In Protective Box | 4 In 1 |